

Features

- Each master can control almost any brand of secondary clock system.
- Master can be programmed and its time updated using unit's keypad or via optional PC software.
- Optional LTR MasterLink Software can control an unlimited number of masters connected directly via RS232 or RS 485 or remotely using an optional internal modem.
- All schedules and setup parameters can be backed up to a PC and restored to the Master
- Automatic daylight savings correction can be pre-programmed.
- Line frequency time base with Quartz backup provides accuracy within 2 minutes per year.
- Large, easy to read LCD with back lighting displays date, time and user prompting information.
- Eight signal circuits operate automatically according to active schedule or manually by keypad.
- Eight separate program schedules provide programming of up to 512 events, 64 per schedule, for audible signal control.
- Each event includes single or multiple days and single or multiple circuits.
- Each event's duration can be independently set from 1 to 99 seconds.
- Circuits can be individually or multiply enabled or disabled for program schedule occurrence.
- A 6-digit pass-code protects all keypad operations, except manual signal circuits.
- A built-in lithium battery keeps time and retains program memory during power failures for up to 10 years.
- The Master Control's time can be synchronized to the atomic clock using the optional PC interface.
- Up to 2 different secondary clock systems can be corrected at the same time, plus additional RS485 correction.
- Holidays and schedule changes can be programmed in advance.
- Unit can be surface mounted, semi-flush mounted or 19" rack mounted using optional brackets supplied.

The perfect tool for maintaining time and schedule accuracy for schools, hospitals airports and industry.

Semi-flush Mount



Surface Mount



Rack Mount



LTR8-512

Specifications

Input Voltage	115 / 240 VAC +/- 10%
Input Frequency	50 / 60 Hz
Input Power	30 Watts Max
Program Memory Retention	10 Year Lithium Battery Backup
Operating Temperature	32° – 175° F
Relative Humidity	5% - 85% non-condensing
Shipping Weight	14 lbs.
Time Base	Calibrated quartz osc. w/ lithium back-up
Time Base Accuracy	+/- 2 minutes per year
Circuits	24 VDC to 240 VAC, 10Amp, Double pole relay contacts (plug-in)
System Clock Correction	Up to 2 correction types running simultaneously plus RS485
System Clock Circuits	0, 2 or 4 plus RS485
Bell Circuits	8 with no clock correction 6 with 1 clock correction 4 with 2 clock correction
Mounting / Dimensions installed	Surface: 7"H x 13"W x 4.52"D Semi-flush: 7"H x 13"W x 1.12"D Rack: 5.2"H x 18.7"W x 7"D
Clock Correction Types	Over 50 clock correction schemes supported
Security	2 levels using 6-digit pass code
Number of Schedules	8
Events per Schedule	64 multi-function
Event Scheduling	Day of Week or "Holiday" Time On Duration Circuit(s)
Signal Duration	0 – 99 seconds
Holidays	Up to 16 pre-programmed
Daylight Savings	Automatic, perpetual based on Country Code
Certifications	UL, cUL, CE, FCC Par-15 Class B FCC Part-68 / Canada ICES-003 Class B (Internal Modem)
Time Display Format	12 hour or 24 hour
Display	LCD with back lighting
Auto-correct after power failure	Yes
Atomic clock synchronization	Yes. Requires optional modem and MasterLink software.
Run multiple schedules at one time	Yes
Pre-programmed schedule changes	Yes. Up to 16 scheduled changes.

GENERAL

All wiring to the AC power mains and secondary equipment (clocks, bells, etc.) connect to terminal blocks within the power/relay module. This is easily done by crimping the (supplied) quick connectors to the wires prior to installation. The LTR8-512 may be configured for power from AC mains of 120/240 volts @ 50/60 cycles. The time base synchronization is normally derived from the AC line, and the system automatically detects the selection of 50Hz or 60Hz.

During power failures, accurate timekeeping is maintained by a quartz crystal time base supported by a Lithium battery backup. When AC power is restored the system's microprocessor calculates the amount of time that secondary clocks were not synchronized and automatically delivers the necessary signals for proper re-synchronization.

Within the unit are eight 120/240 Volt 10 Amp relays, each with an illuminating Indicator to show which may be active. The installer can select from several different programmable combinations.

PHYSICAL

The master is comprised of a display unit and a power/relay unit that can be assembled in several different configurations. The unit is available in single assemblies such as a rack mount, semi-flush, surface mount, or a dual assembly with cable to permit surface mounting the display unit and placing the power/relay unit up to 8ft. away (in drop ceiling or under raised floor). The front panel includes an easy to read digital display and lighting indicators to show which of the 8 control relays are on. A 12-button keypad and a series of user-friendly programming menus make programming the system a simple task.

Installation Diagrams

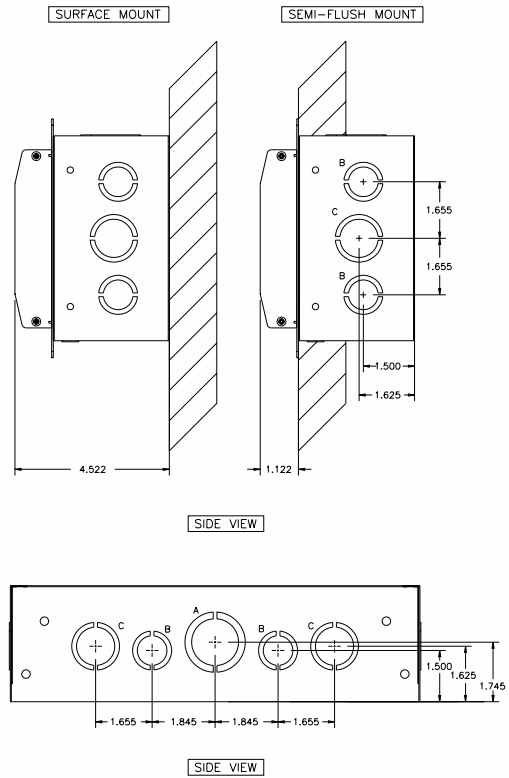
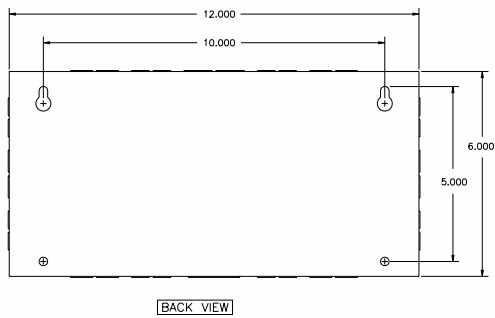
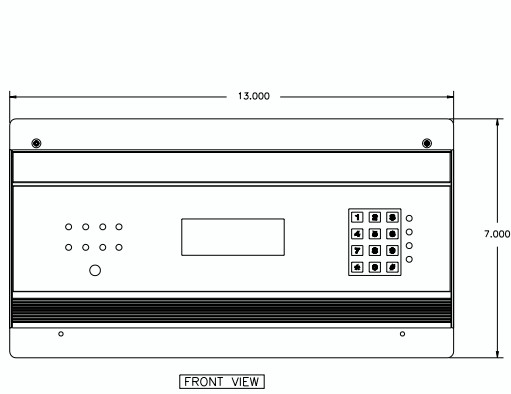

RACK MOUNT

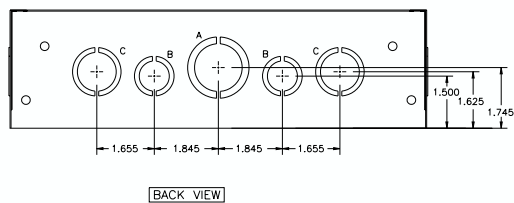
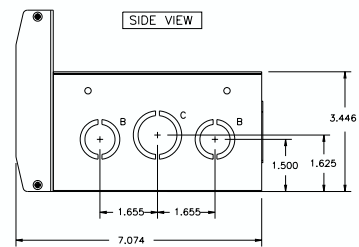
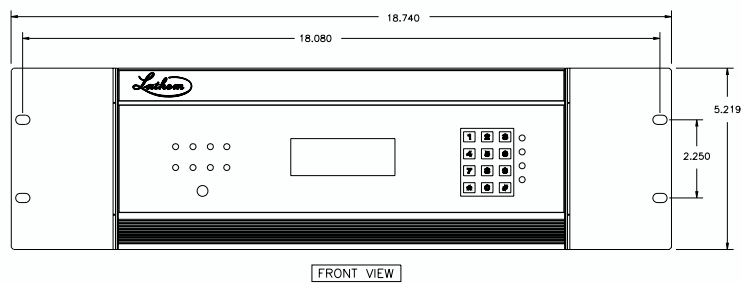

for LTR-512 with 115VAC sync wired clocks and bells.

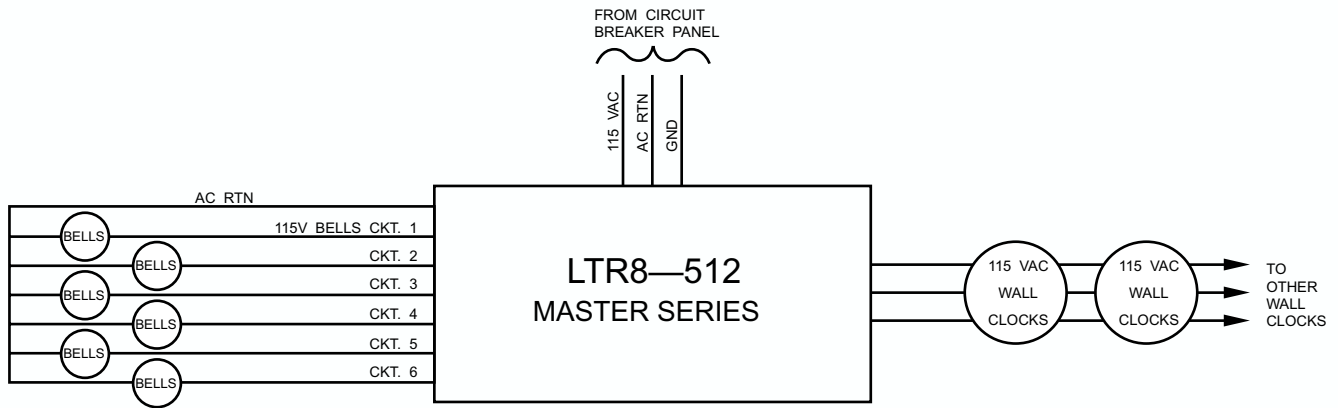

Optical PC Communications Diagram

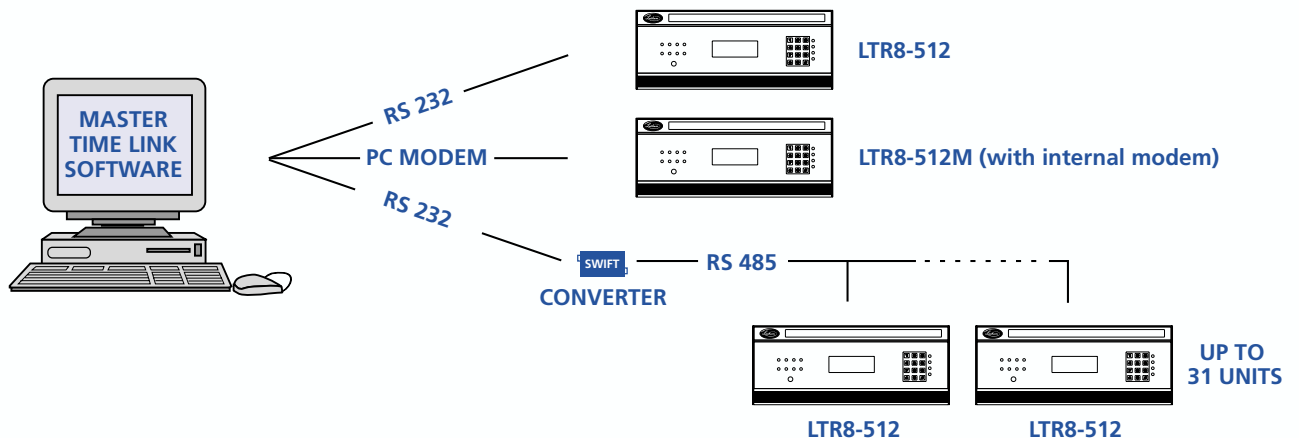

AUTOMATED BUSINESS MACHINES, INC.

6073 NW 167th Street, Suite C-24
 Miami, FL 33015-4347
 www.abmmiami.com

(305) 620-0020 • (954) 739-1222
 (561) 833-9044 • (800) 446-5501

fax (305) 620-2201 • sales@abmmiami.com



LATHEM TIME



200 Selig Drive S.W. • Atlanta, Georgia USA • PH: 1-800-241-4990 FAX: 1-800-252-2208